

Positioning drives

DC motor, brushless

Absolute multiturn position detection, Profibus-DP

MSIA 68 - bevel gear transmission W3 Profibus



MSIA 68 with bevel gear transmission W3 connection axial

Technical data - electrical ratings

Voltage supply	24 VDC $\pm 10\%$
Current consumption	≤ 14 A
Nominal current	5.5 A
Starting current	Charging current capacitor 1500 μ F
Operating current typ.	≤ 100 mA
Positioning resolution motor	0.02 $^\circ$
Positioning accuracy motor	± 1 $^\circ$
Repeatability motor	0.3 $^\circ$
Number of turns	262144 / 18 bit
Commutation	Sine
Undervoltage shutdown	≤ 11.5 V
Terminating resistor	External (see accessories)
Controller	Integrated position and speed regulator (4Q)
Sensing method	Magnetic
Number of pole pairs	2 = 4 poles
Reverse polarity protection	Bus electronics
Overheat protection	112 $^\circ$ C (final power output circuit)
Interference immunity	DIN EN 61000-6-2
Emitted interference	DIN EN 61000-6-4

Features

- Positioning drive with worm gear transmission bevel geared shaft
- Profibus-DP
- Brushless DC motor
- Absolute multiturn position detection
- Nominal power output 80 W
- 4 inputs programmable
- Separate communication and power supply
- Manual positioning operations

Optional

- Holding brake

Technical data - mechanical design

Dimensions	$\varnothing 68$ mm
Shaft type	$\varnothing 12$ mm (through hollow shaft)
Operating speed	≤ 4200 rpm
Nominal speed	3900 rpm
Nominal power output	92 W
Nominal torque	0.225 Nm
Starting torque	≤ 0.68 Nm
Service life	20000 h (without gear)
Protection DIN EN 60529	IP 54
Ambient temperature	-15...+40 $^\circ$ C
Isolation class	B (+130 $^\circ$ C, DIN EN 60034-1)
Rotor moment of inertia	588 gcm ²
Connection	Connector
Resistance	DIN EN 60068-2-6 Vibration DIN EN 60068-2-27 shock
Self-locking in de-energized state	< 0.02 Nm
Shaft surface	Through-groove for key only
Manual shaft alignment	Yes
Material	Housing: Aluminium and zinc diecast
S1 continuous operation	DIN EN 60034-1
S3 intermittent operation	Power-on time 25 %, run time 1 min
Instruction	Nominal data at +40 $^\circ$ C ambient temperature for gearless motor. Service life at operating factor = 1.

Positioning drives

DC motor, brushless

Absolute multiturn position detection, Profibus-DP

MSIA 68 - bevel gear transmission W3 Profibus

Part number

MSIA 68P2P 12-N64 C

Gear
reducer

000 Without gear transmission
007 7 : 1
020 20 : 1
038 38 : 1
100 100 : 1

Gearing variant

K0 Without gear transmission
W3 Bevel gear transmission with hollow shaft ø12 mm

Protection

C IP 54

Connecting direction

A Axial
R Connection on 3:00 o'clock position, radial*
S Connection on 6:00 o'clock position, radial*
T Connection on 12:00 o'clock position, radial*
U Connection on 9:00 o'clock position, radial*

Accessories

Connectors and cables

10164870	Female connector D-SUB, 9-pin, shielded, straight, voltage supply / I/Os, cable 5 m
10153493	Female connector D-SUB, 9-pin, straight, voltage supply and I/Os without cable
10145023	Female connector D-SUB, 9-pin angled
10163483	Female connector D-SUB Kit, IP 65, 9-pin, straight
11002151	Cable, 10-wire, shielded, voltage supply and I/Os
10159389	Cable with male/female M12, Profibus, shielded, straight, B-coded, 0.3 m (stub line)
10157911	Cable with male/female M12, Profibus, shielded, angled, B-coded, 2 m
10157912	Cable with male/female M12, Profibus, shielded, angled, B-coded, 5 m
10157909	Cable with male/female M12, Profibus, shielded, straight, B-coded, 2 m
10157910	Cable with male/female M12, Profibus, shielded, straight, B-coded, 5 m
10153970	Female connector M12, 5-pin, straight
10156585	Female connector M12, 5-pin, angled
10153971	Cable connector M12, 5-pin, straight
10156555	Cable connector M12, 5-pin, angled
10153973	T-junction M12 Profibus (2 male/1 female)
10153975	Terminating resistor Profibus
10156807	Cable with connector D-SUB/mating M12, Profibus, straight, B-coded, 3 m

Programming accessories

10147362	CD-ROM with GSD-/EDS-/XML files and user manuals
10154326	USB-to-Profibus adaptor

* When looking at gearing (gearing position 6:00 o'clock with horizontal shaft orientation)

Motor-gearing-combination

Gear ratio	Torque nominal (Nm)		Rotational speed (rpm)		Admitted shaft load (N)		Weight (kg)	Positioning resolution (°)	Recordable revolutions	Max. transmission play (°)	Mmax gear (Nm)	Gear efficiency approx.
	S1	S3	S1	S3	axial	radial						
-	0.23	0.53	3900	3500	40	400	1.9	0.022	262144	-	-	-
7	1.1	2.7	557	500	40	60	2.8	3.1 x 10 ⁻³	37449	0.29	9.7	0.75
20	2.5	5.9	195	175	40	60	2.8	1.1 x 10 ⁻³	13107	0.27	10.3	0.57
38	4.0	9.3	103	92	40	60	2.8	5.8 x 10 ⁻⁴	6899	0.25	10.0	0.47
100	6.3	14.7	39	35	40	60	2.8	2.2 x 10 ⁻⁴	2621	0.24	7.4	0.28

Further motor - gear combinations upon request.

Positioning drives

DC motor, brushless

Absolute multiturn position detection, Profibus-DP

MSIA 68 - bevel gear transmission W3 Profibus

Terminal assignment

Connector – D-Sub, 9-pin

Connector	Signal	Description
Pin 1	+VsE	+24 VDC voltage supply electronic
Pin 2	Input 1	Input programmable
Pin 3	Input 2	Input programmable
Pin 4	Input 3	Input programmable
Pin 5	Input 4	Input programmable
Pin 6	0 VME	0 VDC voltage s. motor / electronic
Pin 7	0 VME	0 VDC voltage s. motor / electronic
Pin 8	+VsM	+24 VDC voltage supply motor
Pin 9	+VsM	+24 VDC voltage supply motor
	Shield	Housing

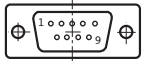

Connector male / female – M12, 5-pin, B-coded

Connector	Signal	Description
Pin 1	+VsDP	VP Profibus +5 VDC (female) ¹⁾
Pin 2	A line green	Cable green / Profibus-DP
Pin 3	0 VDP	DGND Profibus (female) ¹⁾
Pin 4	B line red	Cable red / Profibus-DP
Pin 5	n.c.	–
	Shield	Housing

¹⁾ option: external terminating resistor

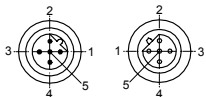

Technical data - communication

Interface	Profibus-DPV0
Output stages	Profibus Insulated RS485 Interface
Profile conformity	Profidrive no. 3 Version 2.0
PPO	Type 2
Cyclic data transfer	Communication according to DPV0
Transmission rate	9.6...12000 kbit/s
Galvanic isolation bus	Yes
Inputs	4 digitally programmable
Switching frequency	<500 Hz
Inputs	
Setting switch	Manual setting of bus address
Potential equalization	Separate screw connection
Status indicator	DUO-LED integrated in housing
Operating modes	Position-controlled operation, Speed-controlled operation, Referencing, External targets, Journey datasets
Diagnostic functions	Temperature control Parameter error Multiturn sensing Self-diagnosis
Programming software	Yes
Factory setting	Node ID 3

Characteristic load curve motor without gears

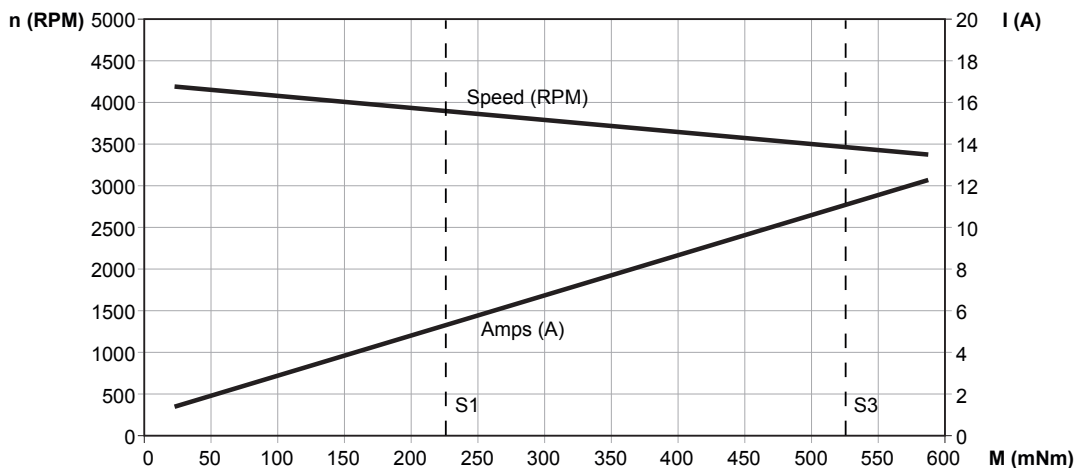

Positioning drives

DC motor, brushless

Absolute multiturn position detection, Profibus-DP

MSIA 68 - bevel gear transmission W3 Profibus

Dimensions

MSIA 68 bevel gear transmission with hollow shaft $\varnothing 12$ mm, connection axial

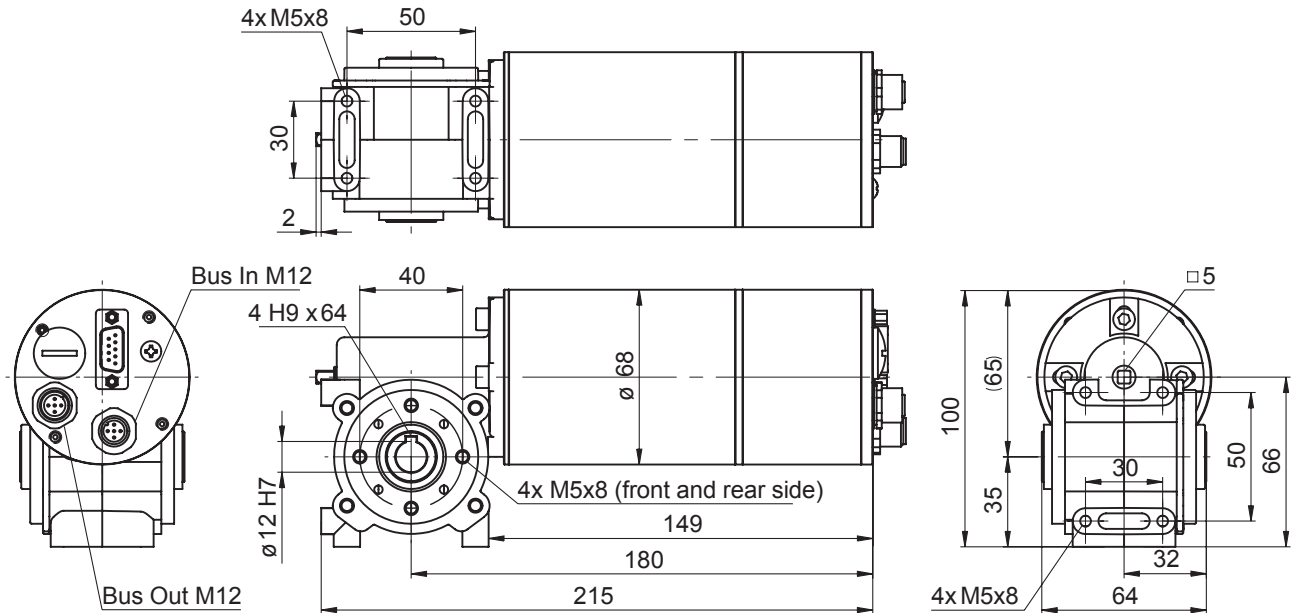

MSIA 68 bevel gear transmission with hollow shaft $\varnothing 12$ mm, connection radial

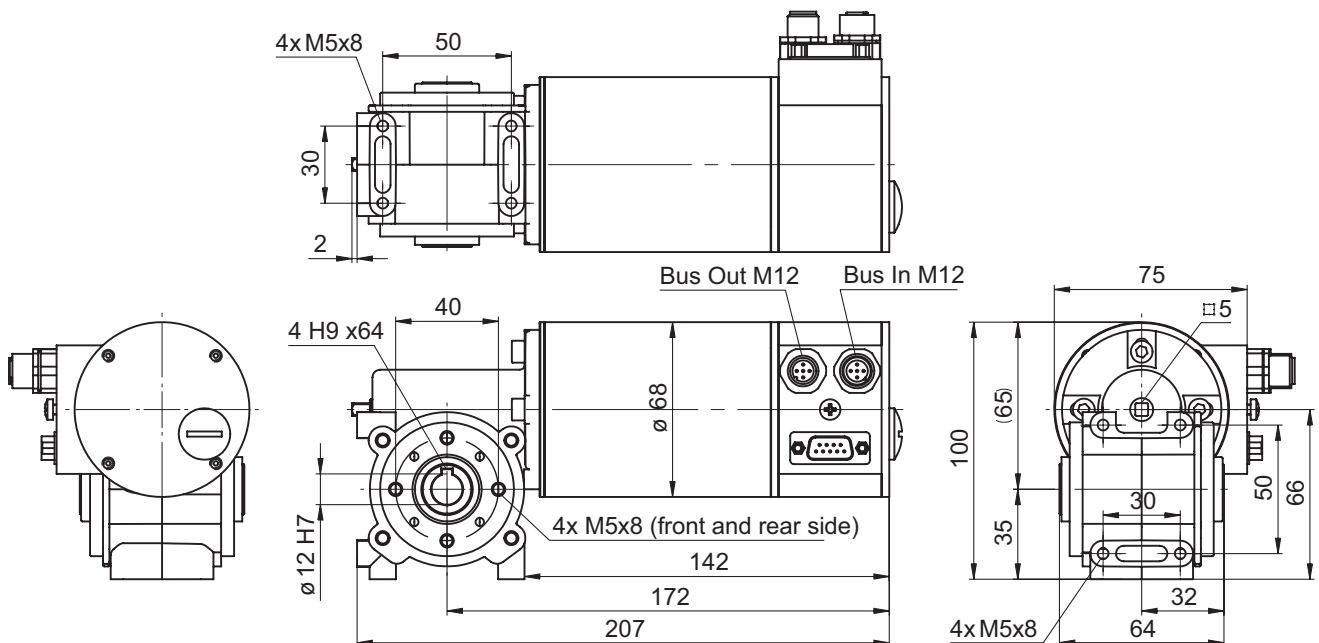

Positioning drives

DC motor, brushless

Absolute multiturn position detection, Profibus-DP

MSIA 68 - bevel gear transmission W3 Profibus

Dimensions

R - Connection on 3:00 o'clock position, radial

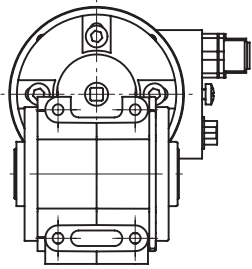

S - Connection on 6:00 o'clock position, radial

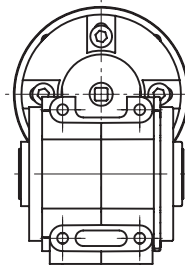

T - Connection on 12:00 o'clock position, radial

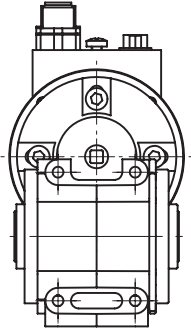

U - Connection on 9:00 o'clock position, radial

